

Top view of block Q1 showing dimensions

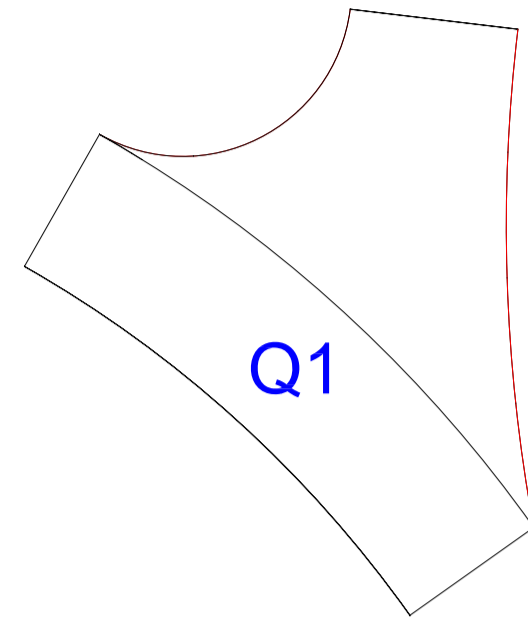

3D solid CAD model supplied as Sheet15.dwg

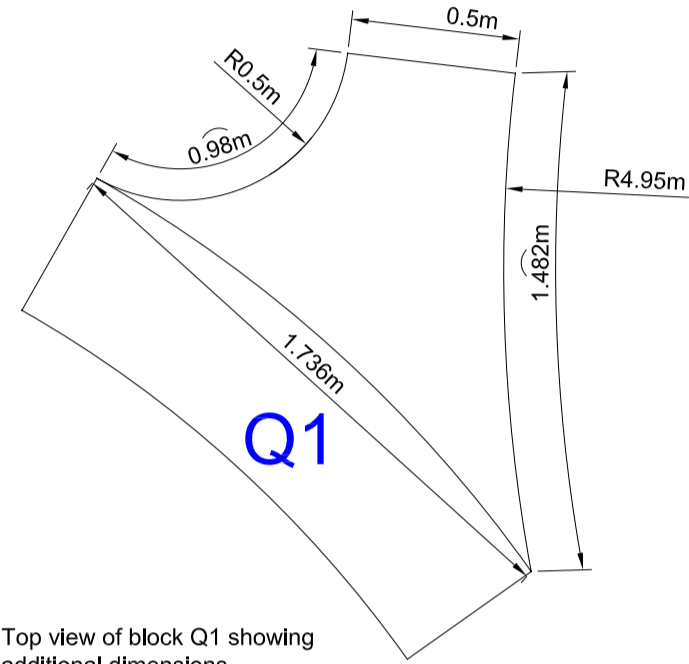

Top view of block Q1 showing additional dimensions

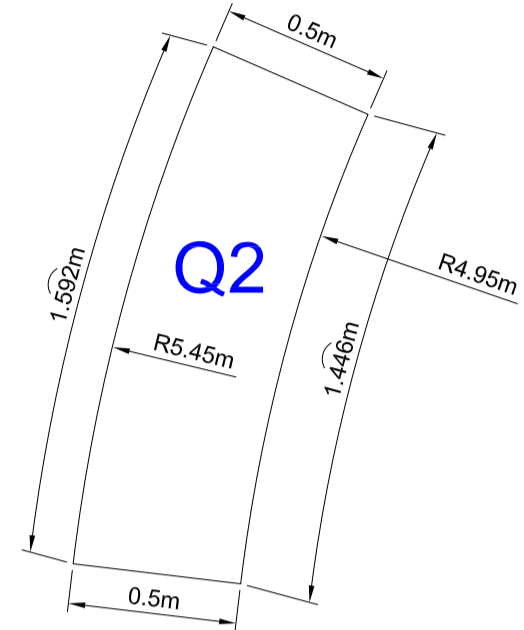

Top view of block Q2 showing dimensions

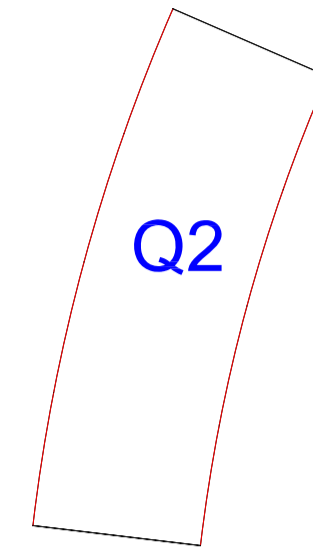

3D solid CAD model supplied as Sheet15.dwg

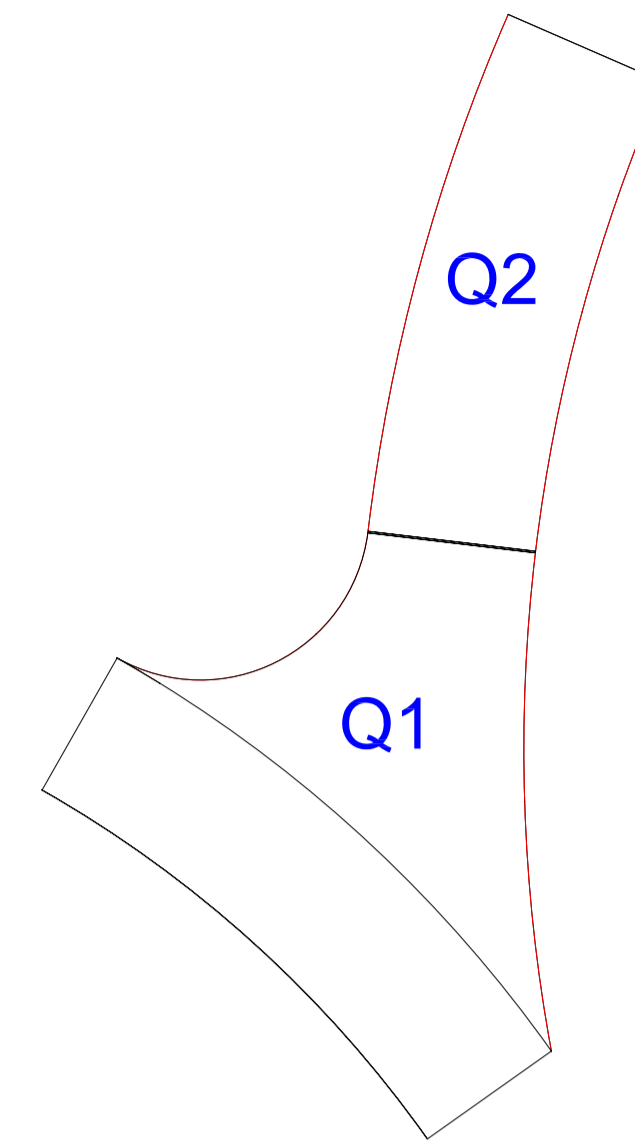

3D solid CAD model supplied as Sheet15.dwg

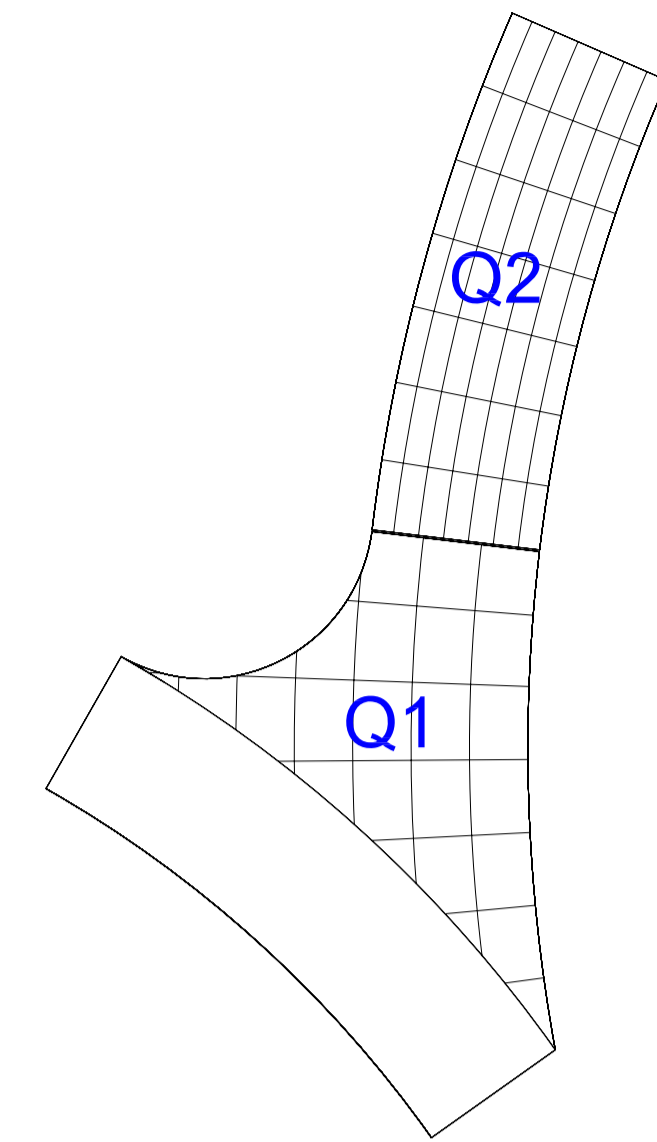

3D surface CAD model supplied as Sheet15.dwg

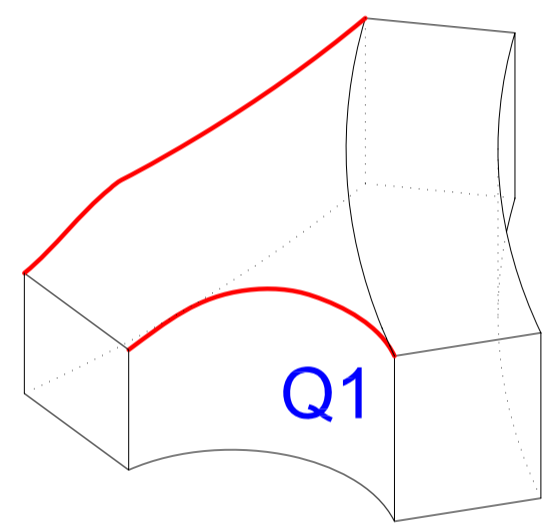

Isometric view showing edges in red colour to be rounded at 30mm radius

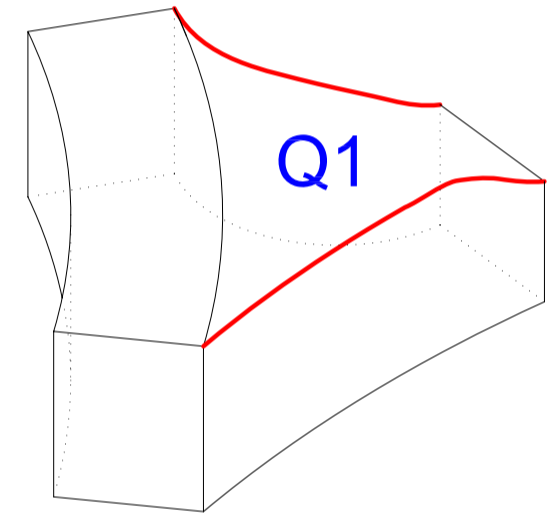

Isometric view showing edges in red colour to be rounded at 30mm radius

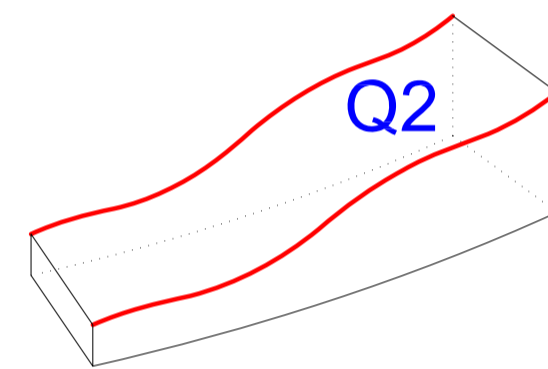

Isometric view showing edges in red colour to be rounded at 30mm radius

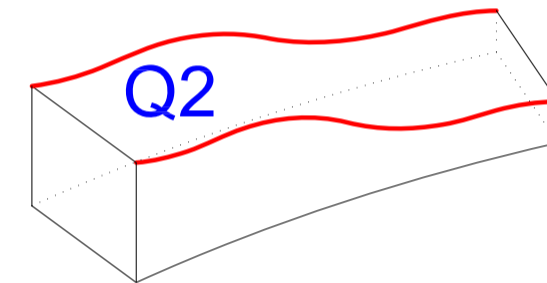

Isometric view showing edges in red colour to be rounded at 30mm radius

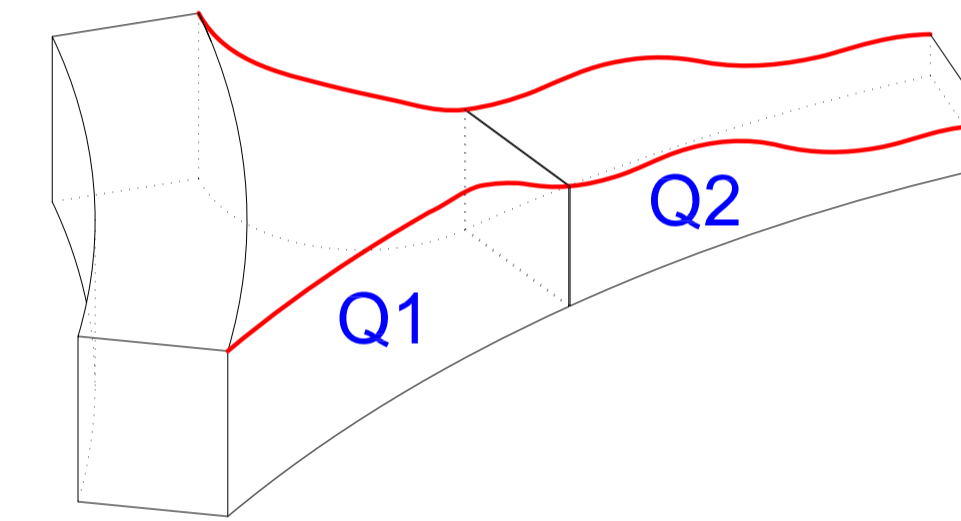

Isometric views of Q1 and Q2

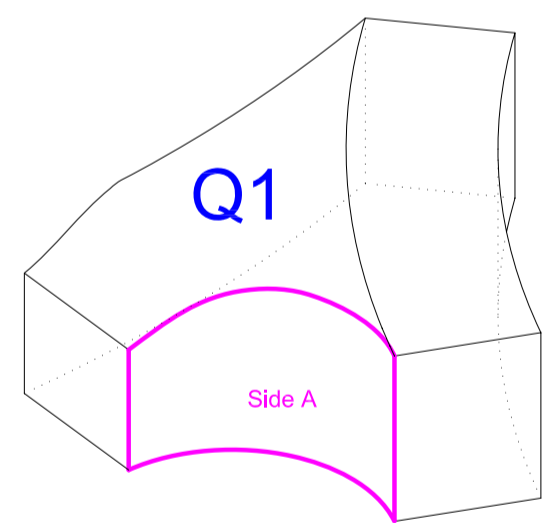

Isometric view of side A for flattened surface shown below

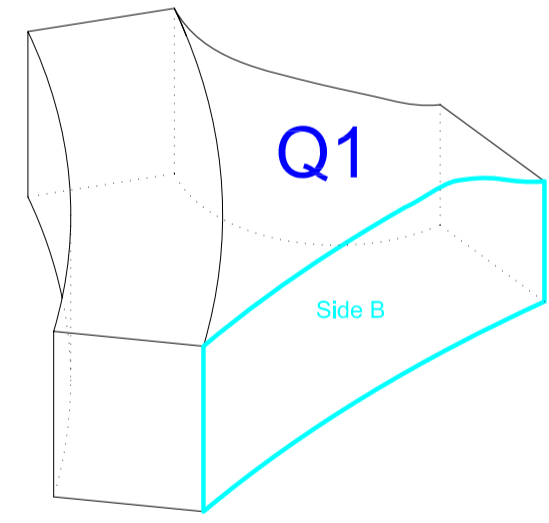

Isometric view of side B for flattened surface shown below

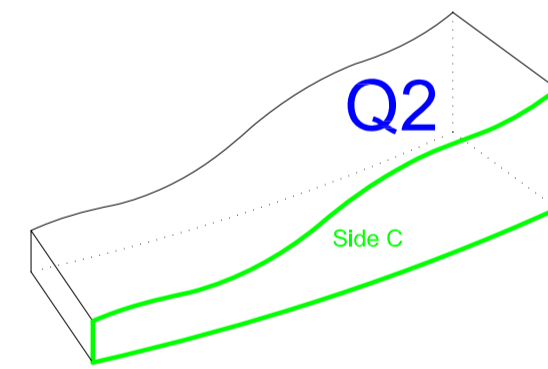

Isometric view of side C for flattened surface shown below

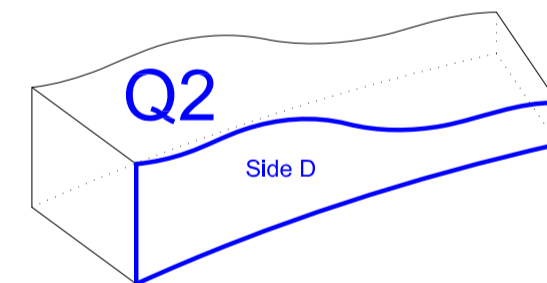

Isometric view of side D for flattened surface shown below

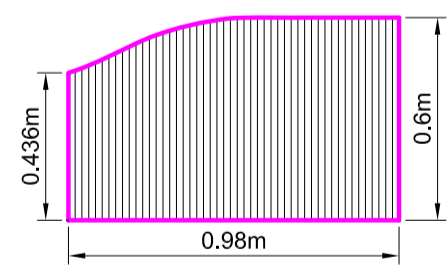

Flattened surface of side A

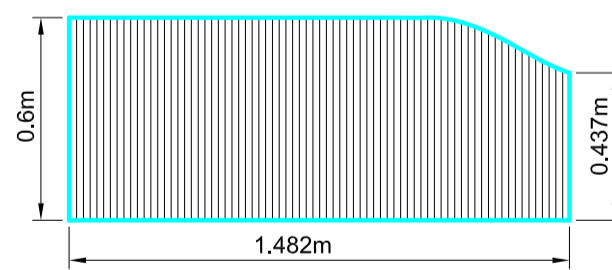

Flattened surface of side B

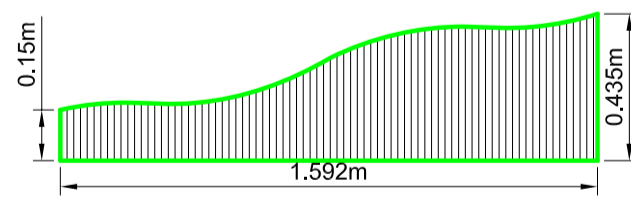

Flattened surface of side C

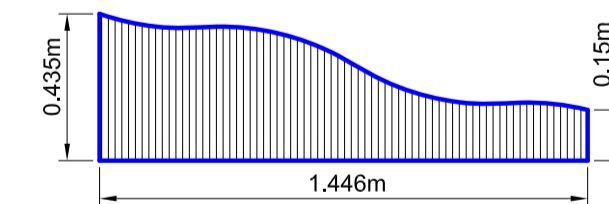

Flattened surface of side D

MATERIAL: CRYSTAL BLACK GRANITE

FINISH: FLAMED

QUANTITY: TOTAL 2 BLOCKS

NOTE: BLOCKS Q1 & Q2 WILL BE EMBEDDED 150mm DEEP, THEREFORE ENDS OF Q2

WOULD BE FLUSH WITH GROUND. EDGE ROUNDING TO REDUCE FROM 30mm

RADIUS TO 0mm RADIUS OVER LAST 100mm OF EDGE BEFORE REACHING GROUND LEVEL

FOR DETAIL SEE SHEET 16

REVISION	DRAWN BY/DATE	CHECKED BY/DATE	APPROVED BY/DATE
A	Halbat Abro		

Based upon the Ordnance Survey mapping with the permission of the Controller of Her Majesty's Stationery Office.
 © Crown copyright.
 Unauthorised reproduction infringes Crown Copyright and may lead to prosecution or civil proceedings. L.B. Lambeth
 100019338 2008

Lambeth Transport
 Transport & Highways
 3rd Floor, Blue Star House
 234-244 Stockwell Road
 London, SW9 9SP
 020 7926 9000

Project		Grass Routes	
Drawing Title		Granite Blocks Q1-Q2 Schedule - Sheet 15	
Purpose	INFORMATION	Draft	Scale
Issuing Office	BLUE STAR HOUSE	Issue	NTS @ A1
Telephone	020 7926 9000	Drawing number	Version
		-	1